

INSTALLATION INSTRUCTIONS: 12V HINGED PATHLIGHTS

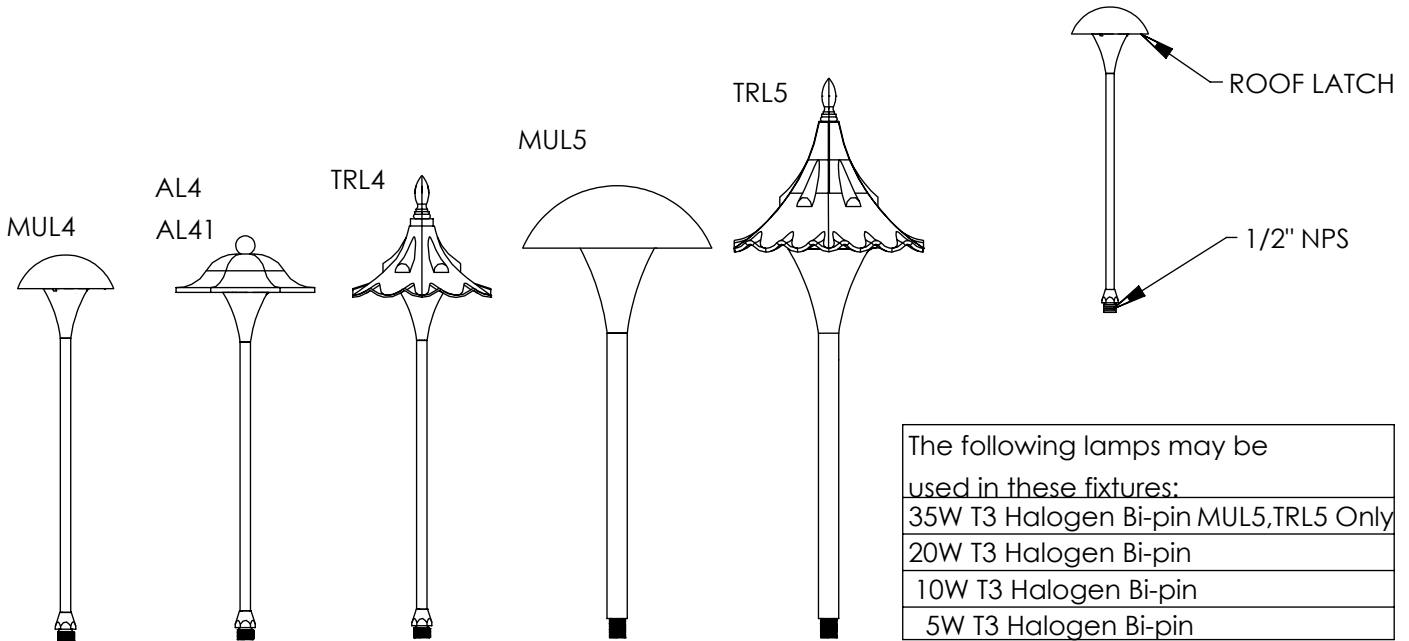

! SAFETY WARNING:

ALWAYS TURN FIXTURE OFF/DISCONNECT POWER AND ALLOW TO COOL BEFORE PERFORMING ANY MAINTENANCE, INCLUDING RELAMPING AND CLEANING!

This fixture can become very HOT! The fixture housing and lens, especially if it is glass, can become hot enough to blister hands. Attention should be paid to where the fixture is mounted, particularly if it can be touched by children or pets. To help prevent premature failure, decreased performance, overheating and risk of fire, keep fixture and lens clean and free of leaves, mulch, debris, and mineral deposits from water. The fixture and lens can be cleaned using a soft cloth and a solution of mild liquid soap and warm water. Wipe clean and dry with a soft, lint-free dry cloth. Avoid polishing fixture or lens.

FOR USE ONLY WITH LOW VOLTAGE LANDSCAPE LIGHTING POWER UNITS THAT ARE RATED MAXIMUM 25 AMPS, 15 VOLTS PER CIRCUIT.

Do not install fixture within 10 feet (1.52 meters) of a pool, spa or fountain.



This fixture is intended for installation in accordance with the National Electrical Code and local code specifications. Failure to adhere to these codes and instructions may result in serious injury and/or damage to the ballast and void the warranty. These instructions do not purport to cover all details or variations in equipment, nor to provide for every possible contingency related to installation, operation, maintenance, or mounting situation. Should specific problems occur that are not addressed by these instructions, contact your Sales Representative or distributor for assistance. Retain these instructions for future reference.

INSTALLATION INSTRUCTIONS

1. Make sure power is turned OFF before installing or servicing the fixture.
2. This fixture must be mounted to a junction box or mounting stake that is UL listed for low voltage and wet locations. Mounting stakes S1, S6, S7, S8, and TS375-12 may be used.
3. Route the wires from the fixture through the stem (order separately) and thread stem into fixture.
4. Insert fixture wire through 1/2" NPS hole in stake cap and screw fixture into cap.
5. Wire fixture to supply cable with low voltage connector (included) by following the instructions below.
6. Attach stake cap to stake, being careful not to pinch wire.
7. Remove the (2) screws that hold the roof to the cage and access the socket. Install T3 bi-pin lamp (20W max, 20W lamp included) and reassemble fixture.
8. Turn power ON.

LOW VOLTAGE CABLE CONNECTOR INSTRUCTIONS

Low voltage cable connector to be used with 10 or 12 gauge supply cable and 18 gauge fixture cable. Hadco recommends using SPT-3 water resistant (marked "WA", "W" or similar marking) supply cable such as our SCW500-10 or our SCW100-12. Hadco also recommends ordering the entire system, which includes the power console (maximum 25 Amps, 15 Volts per circuit), fixture(s) (low voltage cable connector included) and supply cable to ensure proper installation and operation.

When using our supply cable, it can be laid on top of the ground, placed under "ground cover" (that is, shallow burial less than 6 inches or 15.2 cm deep), or directly buried in accordance with the NEC. If not using our cable, per UL 1838-Standard for Low Voltage Landscape Lighting Systems, the secondary cable must be SPT-3 or suitable for wet locations, sunlight resistant and direct burial per UL 493 and sized per UL 1838, and it must be buried less than 6 inches (15.2 cm).

Hadco recommends a minimum depth of 4 inches when burying in the lawn to prevent damage from aerators or other lawn plugging equipment.

The 18 gauge fixture cable (provided with fixture) must be protected by routing in close proximity to the fixture or secured to a building structure such as a house or deck. The fixture cable must be cut off so that it is connected to the low voltage cable connector within 3 inches (7.6 cm) of the fixture or the building structure. When making an underground connection to the 10 or 12 gauge supply cable (not provided), the fixture cable must not be buried more than 3 inches (7.6 cm).

1. Connect the supply cable to the terminals on the power console (transformer) and turn ON.
2. Disassemble the connector by removing the Phillips head screw.
3. Inspect the connector to ensure the prongs are straight. If the prongs are bent, straighten with pliers.
4. Insert the end of the fixture cable into the square opening in the connector body. Bend wire over so that wire is laying in the recess marked '18 GA'. This will help hold the wire in place while performing steps 5 and 6. Only 2-wire cable is to be used and the common (smooth) wire and hot (ribbed) wires must be oriented as shown.
5. Press the supply cable into the recess marked '10,12/2 GA' on the connector body. Again the common (smooth) wires and the hot (ribbed) wires must be oriented as shown.
6. Press the connector cover onto the connector body, making sure the screw holes line up with each other.
7. Assemble the connector by tightening the Phillips head screw. NOTE: Make sure the metal prongs in the connector pierce all 4 wires; the fixture will light as the prongs pierce the wires.

