

INSTALLATION INSTRUCTIONS

MasterSeries® 860

Reduced Pressure Zone Assemblies

Sizes: ½" – 2" (15 - 50mm)

MASTER series®

Installation Instructions

1. Consult local codes for specific installation requirements and restrictions applicable to your area. It is recommended that system supply pressure be at least 20 psi (138 kPa).
2. These instructions apply to models 860, and 860U, sizes ½" - 2" (15 - 50mm) only. The valves may be installed only in the orientation/flow direction as shown.
3. THE VALVE ASSEMBLY MUST BE INSTALLED WHERE RELIEF VALVE DISCHARGE WILL BE ACCEPTABLE, OR WHERE RELIEF DISCHARGE CAN BE COMPLETELY DRAINED. The valve assembly must be installed where it is accessible for periodic testing and maintenance. Clearances shown in the installation views apply to exterior, interior and pit/vault installations and are only recommendations. These minimums do not apply to removable protective enclosures. Refer to local codes for actual requirements in your area.

Note: The gap drain is not designed to catch the maximum discharge possible from the relief valve. The installation of FEBCO air gap with the drain line terminating above a floor drain will handle any normal discharge or nuisance spitting through the relief valve. However, floor drain size may need to be designed to prevent water damage caused by a catastrophic failure condition. Do not reduce the size of the drain line from the air gap fitting.

4. PRIOR TO INSTALLING THE VALVE INTO THE LINE, FLUSH THE SUPPLY LINE OF ALL FOREIGN MATERIAL. Failure to flush the supply line may cause the check valves to become fouled and require disassembly and cleaning.
5. After installation SLOWLY fill the assembly with water and bleed air from the body using the #2, # 3 and # 4 test cocks. Test the valve assembly to ensure correct operation.

NOTE: All assemblies are tested at the factory for proper operation and leakage. If the valve does not pass the field test, it is most likely due to a fouled check valve. This is not covered by the factory warranty. The valve cover must be removed and the check seats inspected and cleaned. Any damage or improper operation caused by pipeline debris or improper installation/start-up is not included in the factory warranty.

In case of a possible warranty claim, contact your local supplier or FEBCO Representative. DO NOT REMOVE THE VALVE ASSEMBLY FROM THE PIPELINE.

6. The assembly must be protected from freezing and excessive pressure increases. Thermal expansion or water hammer can cause pressure increases. These excessive pressure situations must be eliminated to protect the valve and system from possible damage.
7. Plastic testcock plugs and tethers are provided (loose in box) for areas that require them.



Typical Installation

Figure 1

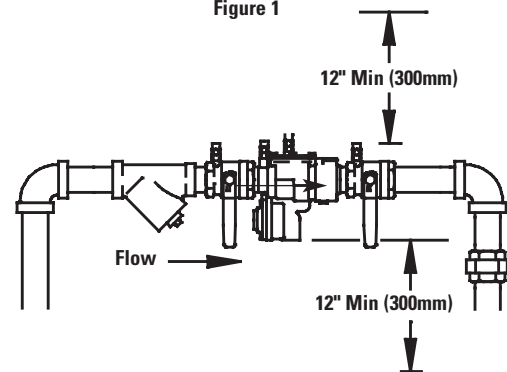
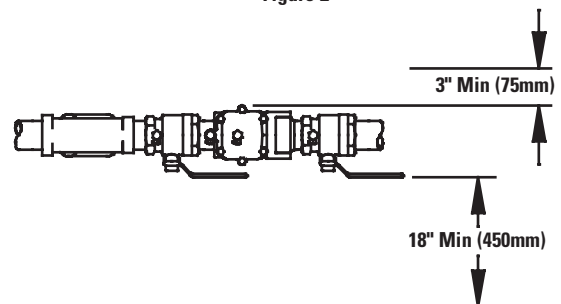

Figure 2



HORIZONTAL INSTALLATION OF THE SERIES 860
(Top view, shown with strainer)

Service and Maintenance

General

1. Detailed maintenance manuals are available from your local FEBCO representative.
2. Rinse all parts with clean water prior to reassembly.
3. DO NOT USE ANY PIPE DOPE, OIL, GREASE OR SOLVENT ON ANY PARTS unless instructed to do so.
4. Do not force parts. Parts should fit together freely. Excess force may cause damage and render the assembly inoperable.
5. Carefully inspect seals and seating surfaces for debris or damage.
6. After servicing, repressurize the assembly and test to ensure proper operation

Check Valve Disassembly

1. Remove cover-bolts using the appropriate size wrench.
2. Remove the spacer between the checks by grasping the flanged end of spacer and pulling straight up.
3. Remove the inlet check assembly by pulling it out from the body bore, in the direction of flow, until it is completely exposed, then lift out of body.
4. Remove the outlet check assembly by placing the tip of a medium sized flat nose screw driver in the slot of the seat and prying the check assembly back until the O-ring is exposed. Then, using your fingers, pull it out from the body bore until it is completely exposed. Lift it from the body.
5. Both check assemblies are disassembled and reassembled in the same manner. To disassemble, grasp the seat section in one hand and the guide section in the other hand. Rotate in a counter-clockwise direction (approximately 1/8 turn) until the two parts disengage.
6. Inspect for debris, damage or fouling of the seat disc. Clean and/or replace parts as required.
7. Reassemble the valve in the reverse order of disassembly.

Relief Valve Disassembly

1. Close the outlet shutoff valve, then close the inlet shutoff valve. Bleed residual pressure from the assembly by opening the #4, #3, and # 2 test cocks in this sequence.
2. Remove the relief valve cover bolts, cover and relief valve assembly in accordance with the FEBCO maintenance manual.
3. Inspect/clean seat surfaces, seals and diaphragm. Replace worn or damaged parts as required.
4. Reassemble the relief valve in the reverse order of disassembly.

Test Procedures

FEBCO recommends the use of the appropriate test method presented in the ASSE Series 5000 manual that is consistent with your local codes.

Troubleshooting

| PROBLEM | CAUSE | SOLUTION |
|--|--|--|
| 1. Continuous relief valve discharge | a. Debris on check seating surface b. Debris on relief valve seating surfaces | Disassemble and clean Disassemble and clean |
| 2. Intermittent relief valve discharge | a. Inlet pressure fluctuations b. Downstream pressure surges | Eliminate fluctuations Eliminate surges |

Limited Warranty: FEBCO warrants each product to be free from defects in material and workmanship under normal usage for a period of one year from the date of original shipment. In the event of such defects within the warranty period, the Company will, at its option, replace or recondition the product without charge. This shall constitute the sole and exclusive remedy for breach of warranty, and the Company shall not be responsible for any incidental, special or consequential damages, including without limitation, lost profits or the cost of repairing or replacing other property which is damaged if this product does not work properly, other costs resulting from labor charges, delays, vandalism, negligence, fouling caused by foreign material, damage from adverse water conditions, chemical, or any other circumstances over which the Company has no control. This warranty shall be invalidated by any abuse, misuse, misapplication or improper installation of the product. **THIS WARRANTY IS IN LIEU OF ALL OTHER WARRANTIES, EXPRESS OR IMPLIED, INCLUDING ANY IMPLIED WARRANTIES OF MERCHANTABILITY OR FITNESS FOR A PARTICULAR PURPOSE.** Any implied warranties that are imposed by law are limited in duration to one year.

Some States do not allow limitations on how long an implied warranty lasts, and some States do not allow the exclusion or limitation of incidental or consequential damages. Therefore the above limitations may not apply to you. This Limited Warranty gives you specific legal rights, and you may have other rights that vary from State to State. You should consult applicable state laws to determine your rights.

